

Operating Instructions Administrator Reference 1 Copier System Edition

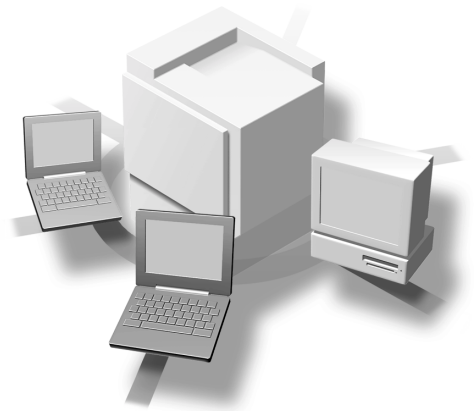

For safety, please read this manual carefully before you use this product and keep it handy for future reference.

Introduction

This manual contains detailed instructions on the operation and maintenance of this machine. To get maximum versatility from this machine all operators should carefully read and follow the instructions in this manual. Please keep this manual in a handy place near the machine.

Please read "Safety Information" in this manual before using this machine. It contains important information related to USER SAFETY and PREVENTING EQUIPMENT PROBLEMS.

Power Source

120 V, 60 Hz, 12 A or more (10A: Printer, 2A: Copier System)

Please be sure to connect the power cable to a power source as above.

Operator Safety:

This machine is considered a CDRH class I laser device, safe for office/ EDP use. The machine contains 7 milliwatt, 645 - 660 nanometer wavelength, AlGaInp Laser Diode. Direct (or indirect reflected) eye contact with the laser beam might cause serious eye damage. Safety precautions and interlock mechanisms have been designed to prevent any possible laser beam exposure to the operator.

Laser Safety:

The Center for Devices and Radiological Health (CDRH) prohibits the repair of laser-based optical unit in the field. The optical housing unit can only be repaired in a factory or at a location with the requisite equipment. The laser subsystem is replaceable in the field by a qualified Customer Engineer. The laser chassis is not repairable in the field. Customer engineers are therefore directed to return all chassis and laser subsystems to the factory or service depot when replacement or the optical subsystem is required.

Important

Contents of this manual are subject to change without prior notice. In no event will the company be liable for direct, indirect, special, incidental, or consequential damages as a result of handling or operating the machine.

Caution:

Use of controls or adjustment or performance of procedures other than those specified in this manual might result in hazardous radiation exposure.

Do not attempt any maintenance or troubleshooting other than that mentioned in this manual. This printer contains a laser beam generator and direct exposure to laser beams can cause permanent eye damage.

Two kinds of size notation are employed in this manual. With this machine refer to the inch version.

For good copy quality, the supplier recommends that you use genuine toner from the supplier.

The supplier shall not be responsible for any damage or expense that might result from the use of parts other than genuine parts from the supplier with your office products.

Trademarks

Microsoft, Windows, and Windows NT are registered trademarks of Microsoft Corporation in the United States and/or other countries.

IPS-PRINT© 1999-2000 Oak Technology, Inc., All rights reserved.

Ethernet is a registered trademark of Xerox Corporation.

Other product names used herein are for identification purposes only and might be trademarks of their respective companies. We disclaim any and all rights involved with those marks.

- The product name of Windows[®] 95 is Microsoft[®] Windows[®] 95.
- The product name of Windows[®] 98 is Microsoft[®] Windows[®] 98.
- The product name of Windows[®] Me is Microsoft[®] Windows[®] Millennium Edition (Windows Me).
- The product name of Windows[®] 2000 are as follows:
Microsoft[®] Windows[®] 2000 Server
Microsoft[®] Windows[®] 2000 Professional
- The product name of Windows NT[®] 4.0 are as follows:
Microsoft[®] Windows NT[®] Server 4.0
Microsoft[®] Windows NT[®] Workstation 4.0

Notes:

Some illustrations in this manual might be slightly different from the machine.

Certain options might not be available in some countries. For more information, please contact your local dealer.

Fax options are not sold in some areas.

Safety Information

When using your equipment, the following safety precautions should always be followed.

Safety During Operation

In this manual, the following important symbols are used:

- | |
|----------------------------------------------------------------------------------------------------------------------------------------------------------------------------------------------------------------------------------------------------------------------------------------------------------------------------------------------------------|
| <p>⚠ WARNING:
<i>Indicates a potentially hazardous situation which, if instructions are not followed, could result in death or serious injury.</i></p> <p>⚠ CAUTION:
<i>Indicates a potentially hazardous situation which, if instructions are not followed, may result in minor or moderate injury or damage to property.</i></p> |
|----------------------------------------------------------------------------------------------------------------------------------------------------------------------------------------------------------------------------------------------------------------------------------------------------------------------------------------------------------|

⚠ WARNING:

- | |
|------------------------------------------------------------------------------------------------------------------------------------------------------------------------------------------------------------------------------------------------------------------------------------------------------------------------------------------------------------------------------------------------------------------------------------------------------------------------------------------------------------------------------------------------------------------------------------------------------------------------------------------------------------------------------------------------------------------------------------------------------------------------------------------------------------------------------------------------------------------------------------------------------------------------------------------------------------------------------------------------------------------------------------------------------------------------------------------------------------------------------------------------------------------------------------------------------------------------------------------------------------|
| <ul style="list-style-type: none">• Confirm that the wall outlet is near the machine and freely accessible, so that in event of an emergency, it can be unplugged easily.• Disconnect the power plug (by pulling the plug, not the cable) if the power cable or plug becomes frayed or damaged.• To avoid hazardous electric shock or laser radiation exposure, do not remove any covers or screws other than those specified in this manual.• Turn off the power and disconnect the power plug (by pulling the plug, not the cable) if any of the following conditions exist:<ul style="list-style-type: none">• You spill something into the equipment.• You suspect that your equipment needs service or repair.• Your equipment's cover has been damaged.• Do not incinerate spilled toner or used toner. Toner dust is flammable and might ignite when exposed to an open flame.• Disposal should take place at an authorized dealer or appropriate collection site.• If you dispose of the used toner cartridges yourself, dispose of them according to local regulations. |
|------------------------------------------------------------------------------------------------------------------------------------------------------------------------------------------------------------------------------------------------------------------------------------------------------------------------------------------------------------------------------------------------------------------------------------------------------------------------------------------------------------------------------------------------------------------------------------------------------------------------------------------------------------------------------------------------------------------------------------------------------------------------------------------------------------------------------------------------------------------------------------------------------------------------------------------------------------------------------------------------------------------------------------------------------------------------------------------------------------------------------------------------------------------------------------------------------------------------------------------------------------|

⚠ CAUTION:

- *Protect the equipment from dampness or wet weather, such as rain, snow, and so on.*
- *You should take care that the power cable will not be damaged under the equipment.*
- *When you disconnect the power plug from the wall outlet, always pull the plug (not the cable).*
- *Do not allow paper clips, staples, or other small metallic objects to fall inside the equipment.*
- *Do not eat or swallow toner.*
- *Keep toner (used or unused) and toner cartridge out of reach of children.*
- *For environmental reasons, do not dispose of the equipment or expended supplies at a household waste collection point. Disposal should take place at an authorized dealer or an appropriate collection site.*
- *Our products are engineered to meet the highest standards of quality and functionality. When purchasing expendable supplies, we recommend using only those specified by an authorized dealer.*
- *The inside of the machine becomes very hot. Do not touch the parts with a label indicating a "hot surface". Touching a "hot surface" could result in a burn. (⚠: means "hot surface".)*
- *To install this machine, contact your service representative. It can be dangerous if electrical equipment is connected incorrectly.*
- *The service representative will install options. Do not loosen or remove any screws used in the rack.*

Note

- To move the machine, contact your service representative.
- The socket outlet on the back of the Scanner Unit is for the printer. Do not use it for other equipment.
- Power Connection: 120 V, 60 Hz, 12 A or more (10A: Printer, 2A: Copier System)
- For safety information, see also the Setup Guide.

How to Read This Manual

Symbols

In this manual, the following symbols are used:

 **WARNING:**

This symbol indicates a potentially hazardous situation which, if instructions are not followed, could result in death or serious injury.

 **CAUTION:**

This symbol indicates a potentially hazardous situation which, if instructions are not followed, may result in minor or moderate injury or damage to property.

* The statements above are notes for your safety.

 **Important**

If this instruction is not followed, paper might be misfed, originals might be damaged, or data might be lost. Be sure to read this.

 **Preparation**

This symbol indicates the prior knowledge or preparations required before operating.

 **Note**

This symbol indicates precautions for operation, or actions to take after misoperation.

 **Limitation**

This symbol indicates numerical limits, functions that cannot be used together, or conditions in which a particular function cannot be used.

 **Reference**

This symbol indicates a reference.

[]

Keys that appear on the machine's panel display.

Keys and buttons that appear on the computer's display.

[]

Keys built into the machine's control panel.

Keys on the computer's keyboard.

TABLE OF CONTENTS

1. Guide to the Machine

Outside: Front and Left	1
Outside: Right	3
Outside: Rear	4
Inside	5
Control Panel	6
Display panel	8
Initial Printer Display	8
Online	9
Offline	10
Initial Document Server Display	11
Common Key Operation.....	11
Changing Modes	12

2. Getting Started

Connecting the Machine	13
Requirements	14
Connection to a Network.....	15
Parallel Connection	16
Connection to IEEE 1394 Interface.....	17
Turning On/Off the Power	19
Turning On the Main Power	19
Turning On the Power	20
Turning Off the Power	20
Turning Off the Main Power	21
Configuring the Network	22
Configuring the Network.....	22
Configuring the Network with the Control Panel	23
Test Print	32

3. Setup Guide for each Network Environment

Printing with a Print Server	33
Printing with a Windows 2000 or Windows NT 4.0 Print Server	33
Printing with a NetWare Print Server	34
Configuring the Printer as a Print Server	34
Printing without Using a Print Server	36

4. Combined Function Operations

- Copy Mode 37**
 - Changing to Copy Mode 37
 - Interrupt copying to make urgently needed copies 37
- Document Server Mode 39**
 - Copying by Using the Document Server 39
 - Storing Documents in the Document Server 40
 - Interrupt the Operating Function and Start Storing 41
- Facsimile Mode..... 42**
 - Changing to Facsimile Mode..... 42
- Printer Mode..... 43**
 - Changing to Printer Mode 43
 - Printing 43
- Scanner Mode..... 44**
 - Changing to Scanner Mode 44
 - Using the Network TWAIN Scanner 44
 - Using the Network Delivery Scanner 44
 - Interrupting Scanning 45
- Multi-Access 47**

5. Appendix

- Information about Installed Software 49**
 - expat 49
 - NetBSD 49
 - JPEG Library 51
- INDEX..... 52**

1. Guide to the Machine

Outside: Front and Left

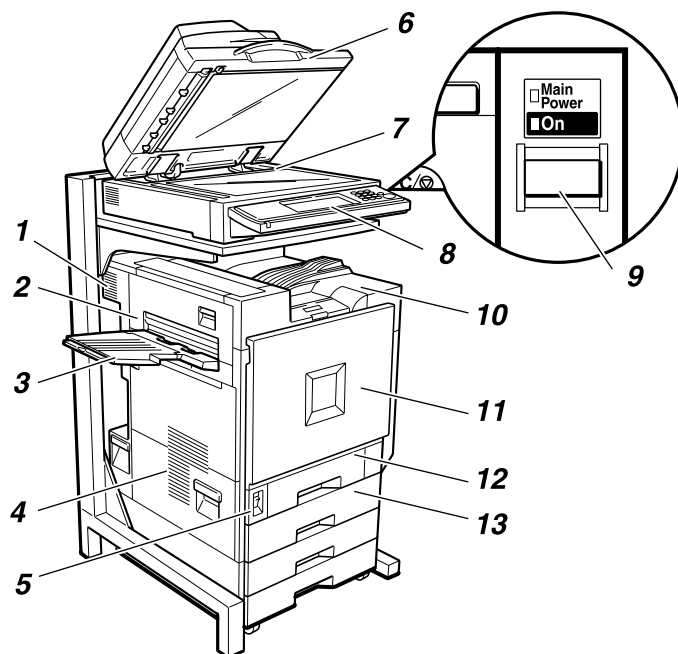

ZFOH010N

1. Ventilator and Dustproof Filter

This hole helps to keep components inside the printer from overheating. Do not block or obstruct the ventilator. A malfunction may occur due to overheating. Remove the ventilator to replace the internal dustproof filter.

2. Upper Left Cover

Open this cover to remove misfed paper or when replacing the Fusing Unit.

3. External Tray

Printed output is stacked here with the print side up.

4. Ventilators

These holes help to keep components inside the printer from overheating. Do not block or obstruct the ventilators. A malfunction may occur due to overheating.

5. Main Power Switch

Use this switch to turn the main power on and off. When the main power switch is turned off, the Main Power indicator goes off and the machine is turned off completely. Normally, do not touch this switch.

6. Exposure Glass Cover (option) or Document Feeder (ADF) (option)

Lower the exposure glass cover over originals placed on the exposure glass for copying or scanning. If you have the document feeder, load a stack of originals here. They will be fed automatically one by one.

(The illustration shows the document feeder.)

7. Exposure Glass

Place originals face down here for copying or scanning.

8. Control Panel

Contains keys and buttons for machine operation and a panel display that shows the machine status.

⇒ p.6 “Control Panel”

9. Operation Switch

Press this switch to turn the power on (the On indicator lights up). To turn the power off, press this switch again (the On indicator goes off).

10. Standard Tray

Output is stacked here with the print side down.

Note

- ❑ If printed A3 short-edge feed or 11x17 short-edge feed papers fall off the standard tray, raise the fence to prevent them from falling.

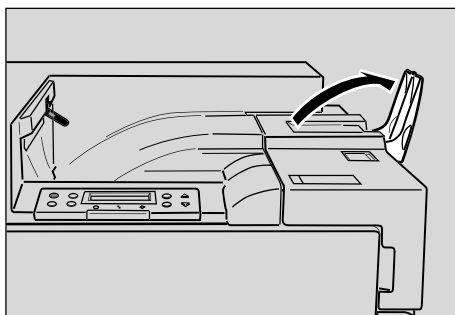

ZGBH010N

11. Front Cover

Open this cover when replacing the Waste Toner Bottle, Development Unit or Photoconductor Unit. A screwdriver is attached to the front cover.

12. Tray 1

Loads up to 500 sheets of plain paper in this tray for printing. Exclusive for 11 × 8 1/2  paper.

13. Tray 2

Loads up to 500 sheets of plain paper in this tray for printing.

Outside: Right

1

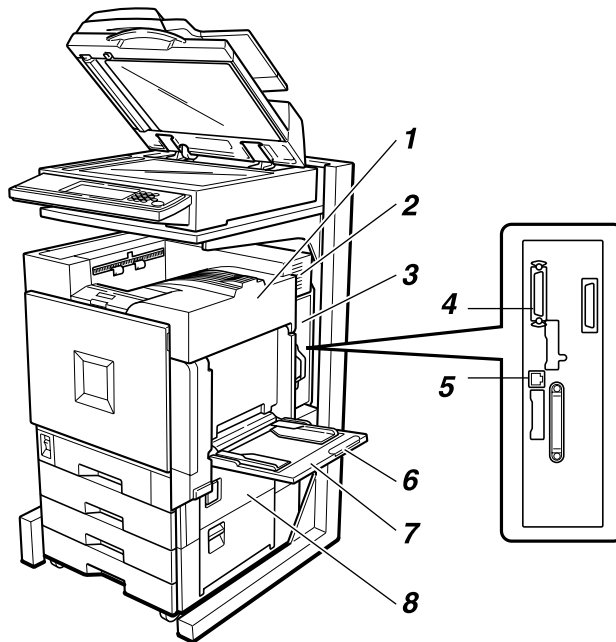

ZFH020J

1. Upper Right Cover

Open this cover to replace toner cartridge.

2. Ventilator

This hole helps to keep components inside the printer from overheating. Do not block or obstruct the ventilator. A malfunction may occur due to overheating.

3. Controller Board

Slide out to install options, such as memory units and interface unit.

4. Parallel Port

Use a parallel cable to connect the printer to the host computer.

5. Ethernet Port

Use a network interface cable to connect the printer to the network.

6. Bypass Tray Extension

Pull out this extension to load paper in the bypass tray when its length is longer than A4 .

7. Bypass Tray

Use to print on thick paper, OHP transparencies, custom size paper, as well as plain paper. Up to 100 sheets of plain paper can be loaded.

8. Right Cover

Open this cover to remove misfed paper.

Outside: Rear

1

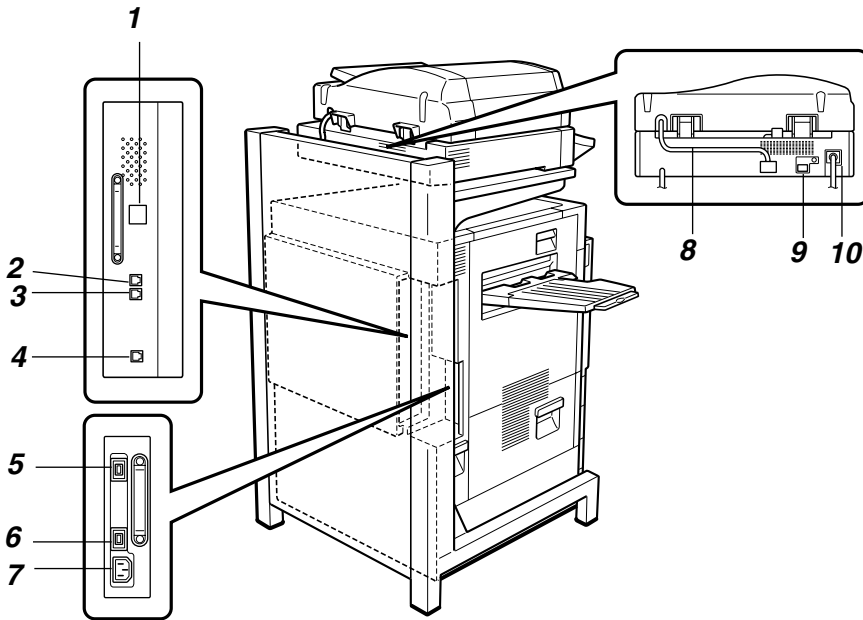

ZFQH040N

1. ISDN Line Connector (option)

⇒Appendix, "Connecting the Machine to the ISDN" in the Facsimile Reference <Advanced Features>

2. External Telephone Connector (option)

⇒Appendix, "Connecting the Machine to a Telephone Line and Telephone" in the Facsimile Reference <Advanced Features>

3. Analog Line Connector (option)

⇒Appendix, "Connecting the Machine to a Telephone Line and Telephone" in the Facsimile Reference <Advanced Features>

4. Extra G3 Interface Unit Connector (option)

⇒Appendix, "Connecting the Machine to a Telephone Line and Telephone" in the Facsimile Reference <Advanced Features>

5. Duplex Unit Port

Connect the cable for the Duplex Reversal Unit to this port.

6. 2 Tray Finisher Port

Connect the cable for the 2 Tray Finisher to this port.

7. Power Port

Connect the power cable to this port and the other cable end to the Printer Power Port.

8. Scanner Unit Connecting Cable

This cable connects the Scanner Unit and the Fax Unit.

9. Printer Power Port

This cable connects the printer and the Scanner Unit.

10. Scanner Unit Power Cable

Connect the power cable to the Scanner Unit and then plug it into a wall outlet.

Inside

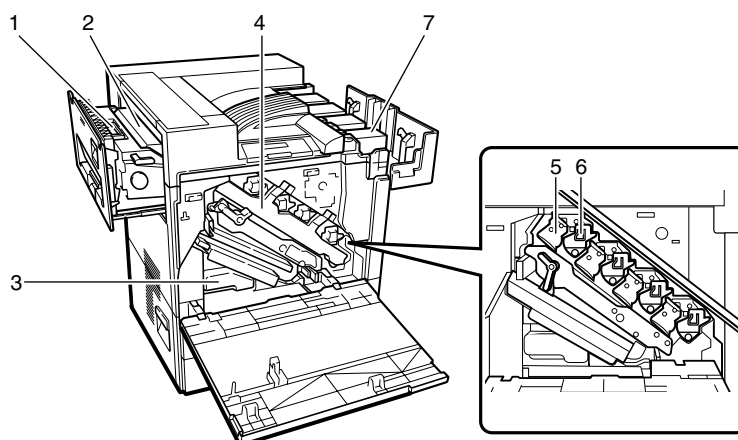

ZDJX703J

1. Fusing Unit

Fuses the image on paper.

When "Fusing Unit Replacement" appears on the panel display, replace this unit.

2. Fusing Oil Unit

Attach to the Fusing Unit.

When "Fusing Oil Unit Replacement" appears on the panel display, replace this unit.

3. Used Toner Bottle

Collects toner that is wasted during printing.

When "Used toner bottle is full." appears on the panel display, replace with a new Used toner bottle.

4. Inner Cover

Open this cover when replacing the Photoconductor Unit or Development Unit.

5. Photoconductor Unit

The printer comes with one black Photoconductor Unit and three color (yellow, cyan, magenta) Photoconductor Units.

When "Replacement of Photoconductor Unit is required." appears on the panel display, replace the appropriate Photoconductor Units.

6. Development Unit

The printer comes with one black Development Unit and three color (yellow, cyan, magenta) Development Units.

When "Replacement of Development Unit is required." appears on the panel display, replace the appropriate Development Units.

7. Toner Cartridge

Loads from the printer rear in the order of magenta (M), cyan (C), yellow (Y), and black (K).

When "Add Toner" appears on the panel display, replace the appropriate toner cartridge.

Control Panel

The illustration of the control panel will vary depending on the installed optional unit. The following illustration has all the options installed.

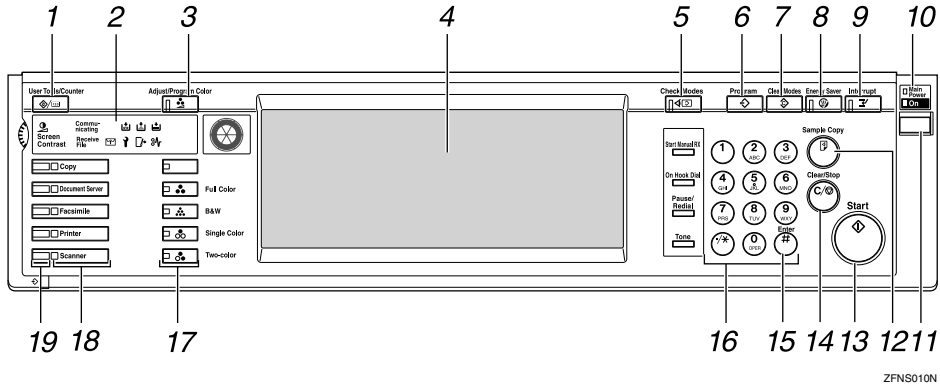

1. [User Tools/Counter] key

- User Tools
Press to change the default settings and conditions to meet your requirements. ⇒"User Tools (System Settings)" in Administrator Reference 2 Copier System Edition
- Counter
Press to check or print the total number of pages.

2. Indicators

Show errors and machine status.

3. [Adjust/Program Color] key

Use this key to register or adjust a color.
⇒Copy Reference <Basic Features>

4. Display panel

Shows operation status, error messages, and function menus.

5. [Check Modes] key

Press to check the entered settings.

6. [Program] key

Press to select the program mode.
⇒Copy Reference <Advanced Features>
⇒Facsimile Reference <Advanced Features>

7. [Clear Modes] key

Press to clear the previously entered settings.

8. [Energy Saver] key

Press to switch to and from Energy Saver mode.

9. [Interrupt] key

Press to interrupt a long job to make copies.

10. Main power indicator and On indicator

The main power indicator goes on when you turn on the main power switch.
The On indicator blinks when the power is on.

Important

- ❑ Do not turn off the power while the On indicator is blinking. Doing so may damage the hard disk.

11. Operation switch

Press this switch to turn the power on (the On indicator goes on). To turn the power off, press this switch again (the On indicator goes off).

Note

- The operation switch is ineffective during a system setting operation.

12. **[Sample Copy]** key

Press to make a single set of copies or prints to check for poor copying or printing before making multiple sets of copies or prints.

13. **[Start]** key

Press to start copying, scanning, or printing documents stored on the Document Server.

14. **[Clear Stop]** key

- Clear
Press to delete a number entered.
- Stop
Press to stop a job in progress.

15. **[#]** key

Press to enter a value.

16. Number keys

Use to enter the desired number of copies and data for selected modes.

17. Color Selection key

When using the copier, use this key to switch between **[Full Color]**, **[B&W]**, **[Single Color]** or **[Two Color]**. ⇒Copy Reference <Basic Features>

18. Function keys

Press the appropriate key to choose any of the following functions:

- Copy
- Document Server
- Facsimile
- Printer
- Scanner

⇒ p.12 "Changing Modes"

19. Function Status indicator

These show the status of the above functions:

- Yellow: the function is selected.
- Green: the function is active.
- Red: the function has been interrupted. Change the panel display with the appropriate function key, and then follow the instructions.

Display panel

1

The screen displayed when the power is turned on is **[Copy]** which is the factory set default.

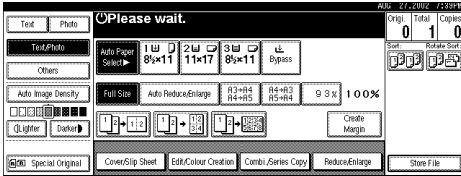

Important

Do not apply a strong shock or force of about 30 N (about 3 kgf) or more to the display panel. If you do, the display can be damaged.

Note

You can change the display to printer priority. For more information, see "User Tools (System Settings)" in Administrator Reference 2 Copier System Edition.

Initial Printer Display

Press **[Printer]** to display initial printer display.

Note

The following illustrations are examples for the machine with the options installed.

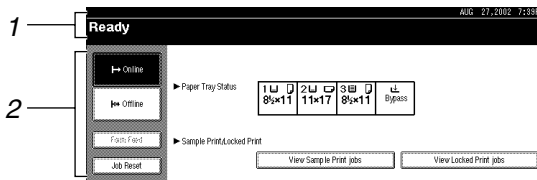

1. Operational status or messages

2. The current settings as well as the functions, which can be selected, are displayed.

Note

The item, which is currently selected or specified, is highlighted.

Online

When the machine is online, it can receive data from the computer.

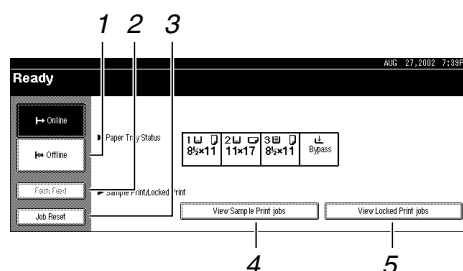

1. [Offline] key

Press this key to switch the printer of-line.

2. [Form Feed] key

Press this key to print all the data left in the printer's input buffer.

Note

When the machine is offline, the key is lightly shaded.

3. [Job Reset] key

Press this key to cancel the current print job.

4. [View Sample Print jobs] key

Press this key to specify Sample Print from your computer. You can print from the second page of the online data and change the printed pages.

5. [View Locked Print jobs] key

Press this key to specify Locked Print from your computer and print the online data.

Offline

When the machine is offline, it cannot receive data from the computer and you can make settings.

1

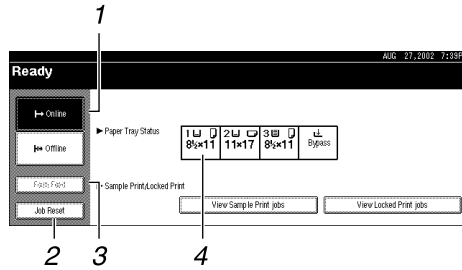

1. [Online] key

Press this key to switch the printer on-line.

2. [Job Reset] key

Press this key while in the Hex Dump Mode to cancel Hex Dump Mode.

Note

- When the machine is offline, the key is lightly shaded.

Note

- If you cannot turn the machine offline, set **[Signal Control]** to **[Printer priority]** in **[Interface Settings/Parallel Interface]** of System Settings. For more information, see "User Tools (System Settings)" in Administrator Reference 2 Copier System Edition.
- If **[Signal Control]** is set to **[Job acceptance priority]** in **[Interface Settings/Parallel Interface]** of System Settings, the machine can receive print jobs and facsimiles from a computer even when offline.

3. [Form Feed] key

Press this key to print all the data left in the printer's input buffer.

4. Paper Tray Status

Shows the input tray and paper sizes, which is selected on the panel display.

Initial Document Server Display

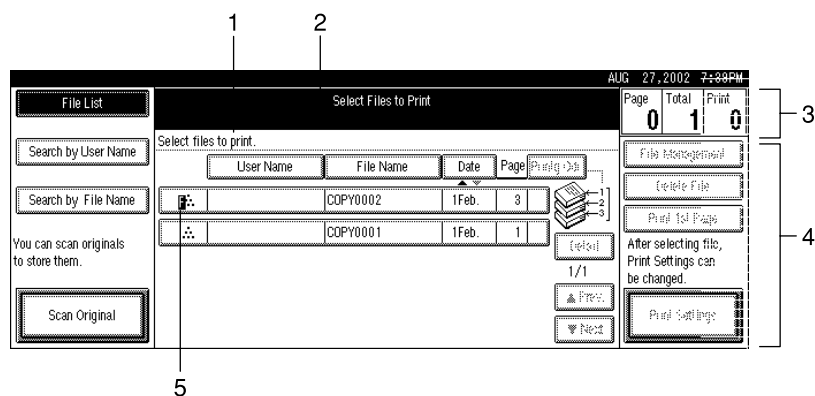

ZEVS120E

1. Operational status or messages
2. The current settings are displayed.
3. Displays printed pages, set pages, and print job pages read into memory.
4. Displays necessary keys for the Initial Document Server Display.
5. Displays stored mode.

Common Key Operation

The following keys can be used in all screens.

◆ Key explanations

[OK]	Acknowledges a selected function or entered values, and then returns to the previous screen.
[Cancel]	Deletes a selected function or entered values, and then returns to the previous screen.
[▲Prev.][▼Next.]	Moves to the previous page or the next page when all the functions cannot be displayed on one page.
[OK][Yes]	Closes message screens.
[Clear]	Clears entered values and does not change the screen.
[Exit]	After setting the selected function or entering a value, the panel display returns to the previous screen.

Changing Modes

You can use this machine not only as a copier, but optionally as a fax, printer and scanner machine as well. Press the **[Copy]**, **[Document Server]**, **[Facsimile]**, or **[Printer]**, **[Scanner]** key to use each function.

1

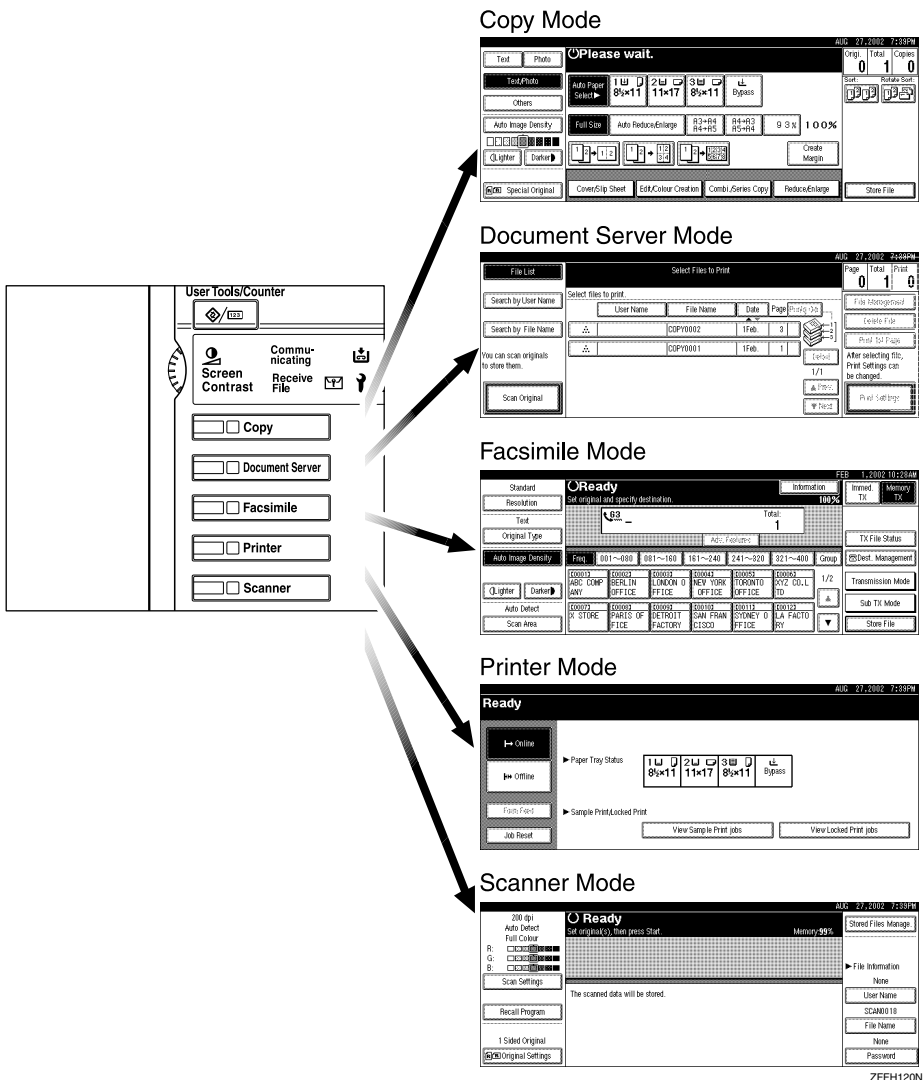

Limitation

You cannot switch modes in any of the following cases:

- When scanning in a fax message for transmission
- During immediate transmission
- When accessing the user tools
- During interrupt copying
- During on hook dialing for fax transmission
- While scanning an original

2. Getting Started

Connecting the Machine

Make sure that the shape and the position of the connector are as shown in the illustration.

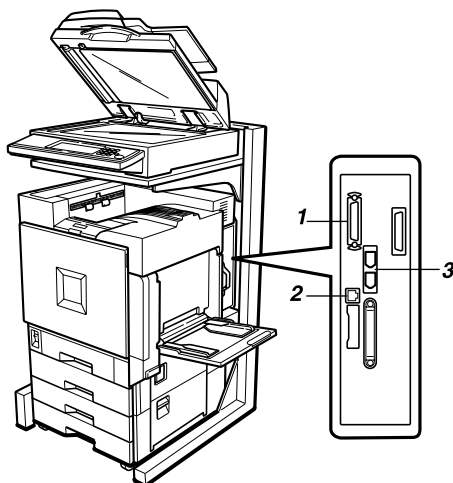

ZFQH021J

1. Parallel Port

This is a connector inserting the parallel interface cable connecting to your computer.

2. 10BASE-T/100BASE-TX

This is the connector inserting a 10BASE-T/100BASE-TX cable. Use this to connect to a network.

Reference

For more information about the parallel port and IEEE 1394 interface connections, see "Connecting the Machine" in the Setup Guide.

3. IEEE 1394 Ports (option)

This is the connector inserting an IEEE 1394 interface cable. Use this to connect the optional 1394 Interface Unit Type 1045 and machine via the IEEE 1394 interface.

Requirements

Requirements

Before using this machine, make sure that all the environmental and electrical requirements have been met. Connect the machine to the host computer using the parallel port, Network Interface Board, or both.

Make sure that all the cables, connectors, and electrical outlets necessary to attach the machine to the host computer or network are present.

Important

- The interface cable is not supplied. It is your responsibility to provide the interface cable appropriate for the computer that you are using.

Reference

For more information about using the parallel port, see the Setup Guide.

For more information about using a network, see p.14 "Network cable requirements".

Network cable requirements

The Network Interface Board can be installed to allow direct connection to an Ethernet network.

The Network Interface Board supports 10BASE-T or 100BASE-TX connections.

You can use the machine in the following network environments:

- Using the appropriate network management software and printer driver
- Attaching the machine to a network computer set up as a server

Client	Windows 95/98/Me, Windows 2000, Windows NT 4.0 *1 , Mac OS *2 , UNIX
Driver	PCL 5c, RPCS™, PostScript 3
File Server	NetWare 3.x, NetWare 4.x, NetWare 5/5.1
Protocol	TCP/IP, IPX/SPX, NetBEUI *3 , AppleTalk

*1 Under Windows NT 4.0, only x 86 CPU is supported.

*2 For information about usable versions of the Mac OS, see the "PostScript Supplement".

*3 To use NetBEUI, use the SmartNetMonitor for Client port.

In a mixed network environment, the protocol switches automatically.

Reference

For more information about network connection settings, see p.33 "Setup Guide for each Network Environment".

Note

- ❑ Consult your network administrator before connecting the machine to a network.
- ❑ Make sure to use a properly shielded and grounded cable (UTP, STP, Category/Type5) for the connection to the host computer (and/or HUB) in order to meet FCC and EMC Directive 89/336/EEC emission guidelines.

Connection to a Network

2

1 Turn off the main power switch.

2 Loop the network interface cable and attach the ferrite core.

Note

- ❑ The network interface cable loop should be about 15 cm (6") (①) from the end of the cable (on the end closest to the machine).

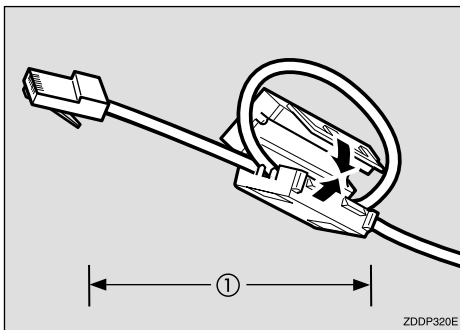

3 Connect the network interface cable to the port on the right side of the printer.

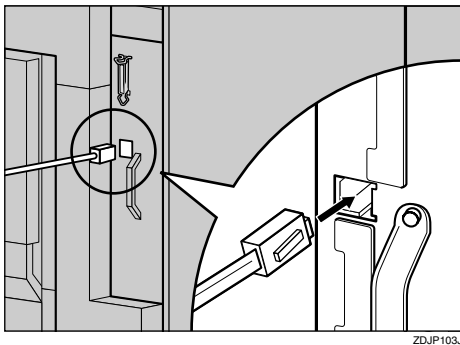

4 Connect the other end of the network interface cable to network equipment, such as a hub.

Reading the LED lamps

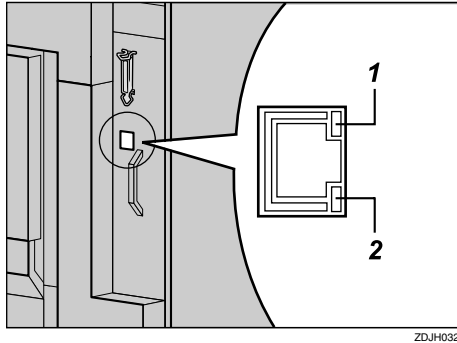

1. Yellow: Lights up when 10BASE-TX is being used. Turns off when 10BASE-T is being used.

2. Green: Lights up when the printer is connected properly to the network.

Parallel Connection

Use an interface cable to connect the printer to the host computer with a parallel connection. The parallel interface cable is not provided with the printer.

 **Note**

- Printer's parallel connection is a standard bidirectional interface. It requires a standard 36-pin parallel cable compliant with IEEE 1284 and a parallel port available on the host computer.
- Use shielded interface cables. Using a cable other than a shielded cable could result in radio interference noise.

1 Turn off the printer and host computer power.

2 Connect the cable to the Parallel Port on the right side of the printer, and then fasten with both clasps.

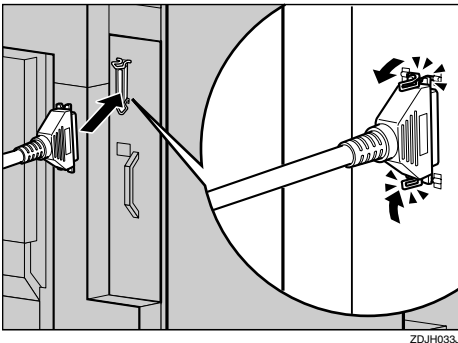

- 3** Connect the other end of the cable to the interface connector of the host computer.

 **Reference**

For more information about settings for printing with a parallel connection, see Printer Client Reference 1.

Connection to IEEE 1394 Interface

2

If the 1394 Interface Unit is installed, you can connect the IEEE 1394 interface cable to the machine.

 **Important**

- To avoid electrical interference, use a shielded cable.

 **Limitation**

- The IEEE 1394 interface can be used only with Windows 2000.

- 1** Turn off the computer power.

- 2** Turn off the main power switch.

 **Important**

- Before turning off the main power switch, see p.19 “Turning On/Off the Power”.

- 3** Connect the interface cable to the 1394 Interface Unit.

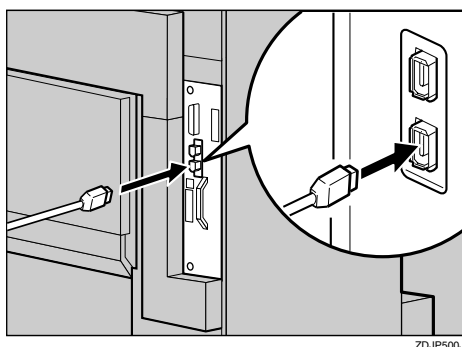

 **Note**

- Either connector can be used.

- 4** Connect the other end of the IEEE 1394 Interface cable to the computer.

- 5** Turn on the main power switch.

6 Turn on the computer power.

The connection between the printer and the computer is complete. Next, install the printer driver.

Reference

For more information about installation of Windows 2000, see Printer Client Reference 1.

Note

- If a printer driver installation dialog appears when you start a computer running Windows 2000, click **[Cancel]**. For more information about installation of Windows 2000, see Printer Client Reference 1.

Turning On/Off the Power

To turn the machine on, press the operation switch.

Note

- This machine automatically enters Energy Saver mode or turns itself off if you do not use the machine for a while. See "*Timer Setting*" in Administrator Reference 2 Copier System Edition.

Power switches

This machine has two power switches.

❖ Main power switch (on the front side of the machine)

When the machine is not to be used for an extended period of time, turn off the main power switch.

Important

- If you leave the main power switch off for more than one hour, all fax files in memory are deleted.

❖ Operation switch (on the control panel)

Press this switch to activate the machine. When the machine has warmed up, you can make copies, send faxes or print.

Turning On the Main Power

- 1** Make sure that the power cord is firmly plugged into the wall outlet.
- 2** Open the switch cover and turn on the main power switch (make sure that the Main Power indicator goes on).

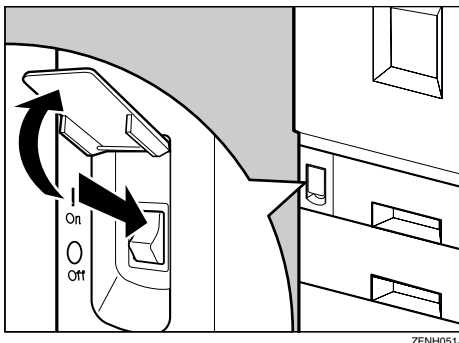

Important

- Do not switch off the main power immediately after it has been switched on. Failure to observe this may result in damage to the hard disk or memory, leading to malfunctions.

Turning On the Power

- 1 Press the operation switch to make the On indicator go on.

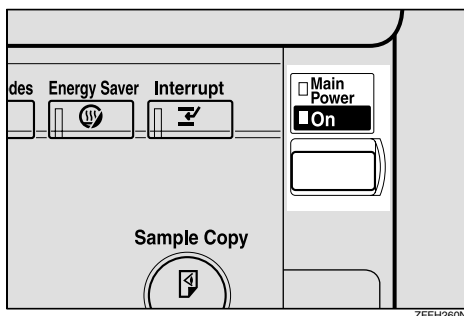

The display panel will come on.

Note

- If the power is not turned on when the operation switch is pressed, check if the main power switch is on. If off, turn it on.
- If the User Code dialog box appears on the display panel instead of the copier display, enter a registered user code, and then press the [#] key. See "User Code" in Administrator Reference 2 Copier System Edition.

Turning Off the Power

- 1 Make sure that the exposure glass or the document feeder is in the right position.
- 2 Press the operation switch to make the On indicator go off.

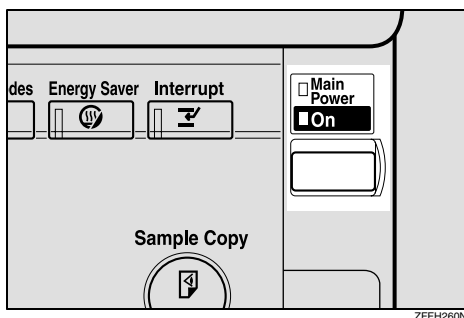

Note

- Even if you press the operation switch, the indicator does not go off and blinks in the following cases:
 - When the exposure glass or the document feeder is open
 - When communication is in progress with external equipment
 - When the hard disk is operating

Tuning Off the Main Power

Preparation

Normally, do not turn off the main power switch. When you have to turn off this switch for some reason, follow the procedure below.

Important

- Do not turn off the main power switch while the on indicator is lit or blinking. This may cause problems in the hard disk or memory.
- Be sure to turn off the main power switch before unplugging the power cord. This may cause problems in the hard disk or memory.
- Make sure that 100% is shown on the display before you turn the main power switch off or unplug the power cord. Fax files stored in memory will be deleted an hour after you turn the main power switch off or unplug the power cord.

1 Make sure the On indicator is off.

2 Open the switch cover and turn off the main power switch (make sure that the Main Power indicator goes off).

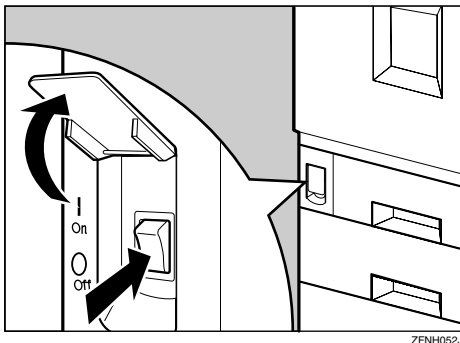

Configuring the Network

Configuring the Network

Preparation

This section describes the network configuration using the control panel of the machine. Make the necessary settings for the functions you use.

Mode	Network Setting
Distribute received fax documents ^{*1}	IP Address, Subnet Mask, Gateway Address, Delivery Server IP Address, Fax RX File Transmission, Effective Protocol (TCP/IP)
Scanner (Network Twain Scanner)	IP Address, Subnet Mask, Gateway Address, Effective Protocol (TCP/IP)
Scanner (Network Delivery Scanner) ^{*2}	IP Address, Subnet Mask, Gateway Address, Effective Protocol (TCP/IP), Delivery Server IP Address, Number of Recalls, Recall Interval time
Printer (TCP/IP) ^{*3}	IP Address, Subnet Mask, Gateway Address, Network Boot, Effective Protocol
Printer (NetWare) ^{*3 *4}	Effective Protocol, NW Frame Type

^{*1} To use this function, the following are required:

- Scanner unit
- Scan Router V2 Professional (option)

^{*2} To use this function, the following are required:

- Scanner unit
- Scan Router V2 Lite (packaged with this machine) or Scan Router V2 Professional (option)

^{*3} Make the necessary settings for your network environment. For more information about settings, see p.23 "Configuring the Network with the Control Panel".

^{*4} Configure the TCP/IP when you use Pure IP of NetWare 5/5.1.

This section describes the basic operation procedure. For more information about the settings, see "*Interface Settings/Network*" in Administrator Reference 2 Copier System Edition.

For a network environment that uses TCP/IP, you can use SmartNetMonitor for Admin (packed with this machine) or the Web browser to configure IP addresses.

Configuring the Network with the Control Panel

This section describes the basic procedures. Please make the appropriate settings for the network you are using.

Important

- These settings should be made by your systems administrator or after consulting with your systems administrator.

The following table shows the control panel settings and their default settings.

◆ Interface Settings/Network

Setting Name	Value	
IP Address	011.022.033.044	
Subnet Mask	000.000.000.000	
Gateway Address	000.000.000.000	
Access Control	000.000.000.000	
Access Mask	000.000.000.000	
Network Boot	None	
Effective Protocol	TCP/IP	Effective
	NetWare	Effective
	NetBEUI	Effective
	AppleTalk	Effective
NW Frame Type	Auto select	
Ethernet Speed	Auto Select	

◆ File Transfer Settings

Setting Name	Value	
Delivery Server IP Address	000.000.000.000	
Fax RX File Transmission	Setting per Line	<ul style="list-style-type: none"> • Port 1: Do not Deliver. • Port 2: Do not Deliver. • Port 3: Do not Deliver.
	Print at Delivery	No
	Files to Deliver	All Files
	Delivery Failure File	—
Recall Interval Time	300 seconds	
Number of Recalls	No	

Network Settings

The following describes the settings required to use the machine in a network. For more information about the settings, see "Interface Settings/Network" in Administrator Reference 2 Copier System Edition.

- 1 Press the **[User Tools/Counter]** key.

2

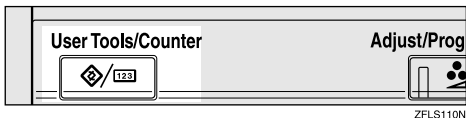

"User Tools/Counter" appears.

- 2 Press **[System Settings]**.

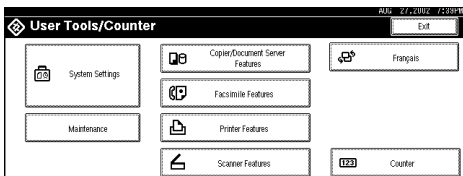

- 3 Press **[Interface Settings]**.

The following screen appears on the panel display.

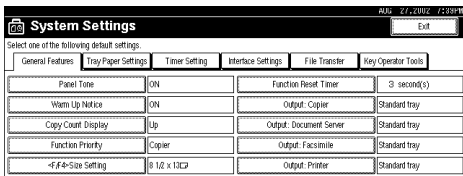

- 4 Make sure that **[Network]** is selected.

The following screen appears on the panel display.

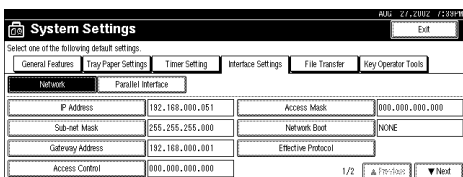

- 5 Press **[Effective Protocol]**.

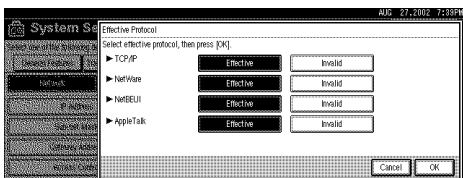

Note

- Consult the network administrator for help with these settings.
- You must configure IP Address to use the TCP/IP protocol. You don't have to configure it if Network Boot is DHCP.
- Press **[Invalid]** for protocols that you don't use.
- Press **[Effective]** for the TCP/IP protocol when you use Pure IP of NetWare 5/5.1.

1 Make sure that the **[Effective Protocol]** key is pressed.

2 Select **[Invalid]** or **[Effective]** for each protocol.

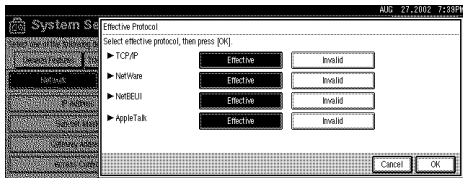

3 Press **[OK]**.

The following operation will be different, according to each protocol.

When Using TCP/IP

1 Make sure that **[Network]** is selected, and then press **[IP Address]**.

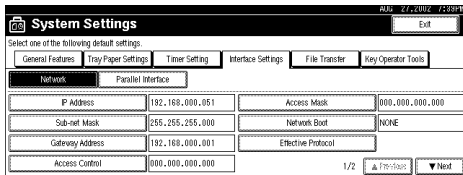

2 Use the number keys to enter the IP address.

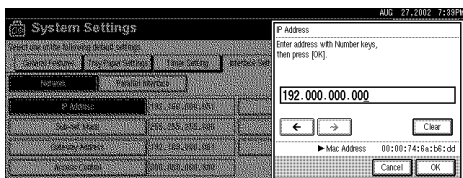
**Note**

- Press the **[←]** and **[→]** keys to move to the next entry field.
- If you enter the wrong IP address, press **[Clear]** and reenter the IP address.

3 Press **[OK]**.

4 Make the **[Sub-net Mask]**, **[Gateway Address]**, **[Access Control]**, and **[Access Mask]** settings. For each item, press the corresponding button on the screen shown in step **1**, and then perform the same procedure as described in steps **2** and **3**.

Acquiring the IP Address from the DHCP Server

To use the DHCP server to acquire the IP address, select **[DHCP]** from **[Network Boot]**.

Note

- You need to set the server when you use DHCP. See "Appendix" in Administrator Reference 2 Copier System Edition.
- To always assign the same IP address to the machine, reserve the IP address for the machine on the DHCP server. See "Appendix" in Administrator Reference 2 Copier System Edition.
- Use the default IP address.

1 Make sure that **[Network]** is selected, and then press **[Network Boot]**.

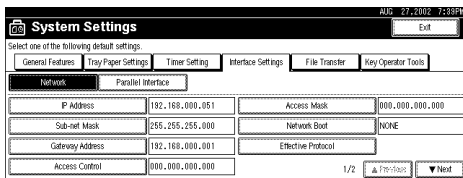

2 Press **[DHCP]**, and then press **[OK]**.

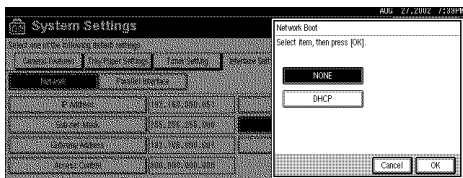

When using NetWare

To use the machine on NetWare, be sure to select the type of **[NW Frame Type]**.

You can select the following frame types:

- Auto select (Default)
- Ethernet II
- Ethernet 802.2
- Ethernet 802.3
- Ethernet SNAP

Note

- Select the same frame type which the file server uses.
- To use the machine in a Pure IP environment on NetWare 5/5.1, select **[Effective]** for the TCP/IP protocol in step 5.

- 1 Make sure that [Network] is selected, and then press [▼Next].

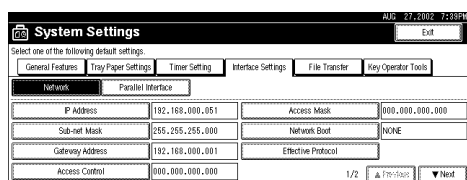

- 2 Press [NW Frame Type].

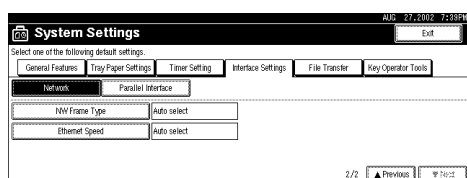

- 3 Select the frame type, and then press [OK].

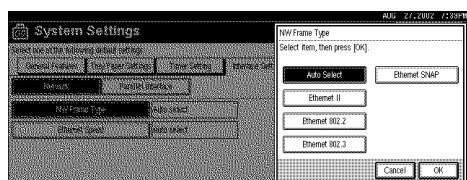

- 6 Press [Exit].

Returns to the [User Tools/Counter] display.

- 7 Press [List/Test Print] to print out the settings.

- 1 Press [Printer Features].

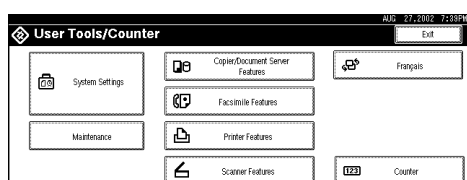

- 2 Press [List/Test Print].

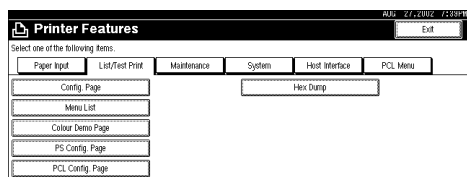

- 3 Press [Config. Page].

The configuration page will be printed.

- 8 Press the [User Tools/Counter] key.

Note

- The settings are applied and the initial display is shown.

File Transfer Settings

Preparation

The File Transfer function requires the optional Hard Disk Unit.

The following describes the File Transfer settings required for sending received facsimile files and sending scanned files using the Scanner function. For more information about the settings, see "User Tools (System Settings)" in Administrator Reference 2 Copier System Edition.

1 Press the **[User Tools/Counter]** key.



"User Tools/Counter" appears.

2 Press **[System Settings]**.

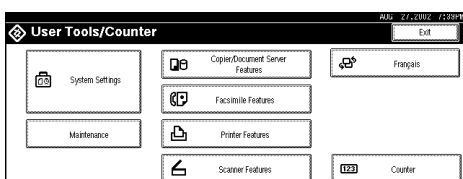

3 Press **[File Transfer]**.

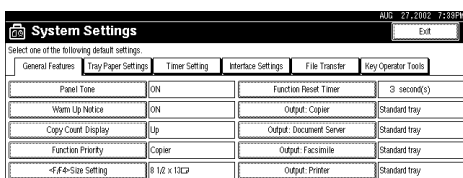

The procedure after this varies depending on the items to be set. Refer to the following procedures, and then make the necessary settings.

- Assigning a Delivery Server IP Address
- Making Settings to Transmit Received Facsimile Files
- Setting the Recall Interval Time
- Setting the Number of Recalls

Note

- After making necessary settings, go to step **4**.

Assigning a Delivery Server IP Address

Note

- You must also set the Delivery Server IP address on ScanRouter V2 Lite/Professional. The relevant setting on the machine will be overwritten by the Delivery Server IP address set on ScanRouter V2 Lite/Professional.

1 Press [Delivery Server IP Address].

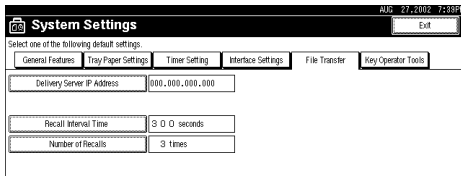

2 Use the number keys to enter the Delivery Server IP address.

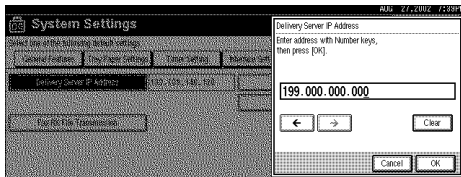

Note

- Press the [←] or [→] key to move to the adjacent entry field.
- To correct the Delivery Server IP address entered, press [Clear], and then enter the correct Delivery Server IP address.

3 Press [OK].

Making Settings to Transmit Received Facsimile Files

1 Press [Fax RX File Transmission].

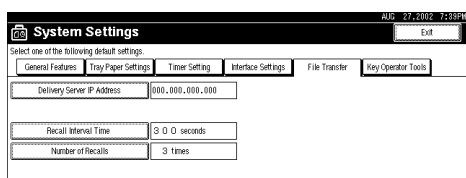

2 Make the following settings as required:

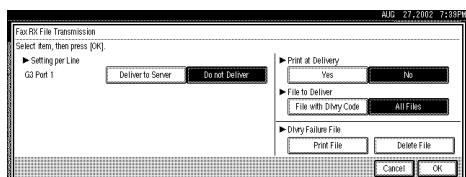

- Setting per Line
- Print at Delivery
- File to Deliver
- Delivery Failure File

3 Press [OK].

Setting the Recall Interval Time

1 Press [Recall Interval Time].

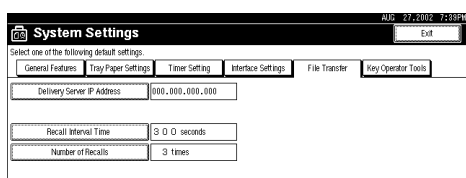

2 Use the number keys to enter the Recall Interval Time.

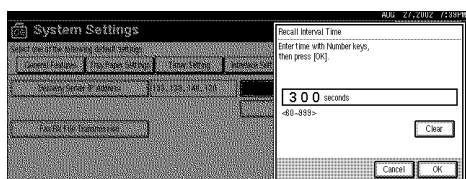

Note

- ❑ To correct the Recall Interval Time entered, press **[Clear]**, and then enter the correct Recall Interval Time.

3 Press [OK].

Setting the Number of Recalls

1 Press [Number of Recalls].

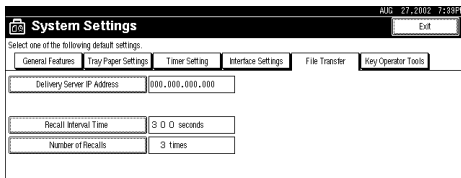

2 To resend files to the Delivery Server, press [Yes].

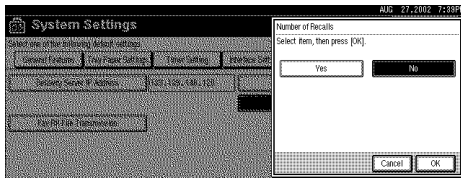

The menu to specify the Number of Recalls appears.

Note

- To not resend files, press [No] and go to step 4.

3 Use the number keys to enter the Number of Recalls.

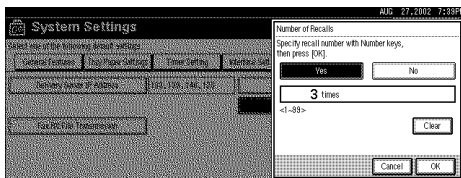

Note

- To correct the entered Number of Recalls, press [Clear], and then enter the correct Number of Recalls.

4 Press [OK].

4 Press [Exit].

5 Press the [User Tools/Counter] key.

The new settings become effective and the display returns to the main function menu.

Test Print

Test print in order to check that the printer prints normally. Test printing checks the printer actions, and does not test the connection to the host computer.

This section describes how to print the configuration page as an example.

1 Press the **[User Tools/Counter]** key.

"User Tools/Counter" appears on the panel display.

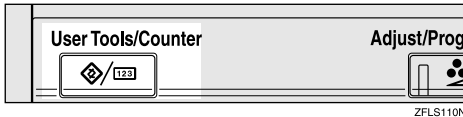

2 Press **[Printer Features]**.

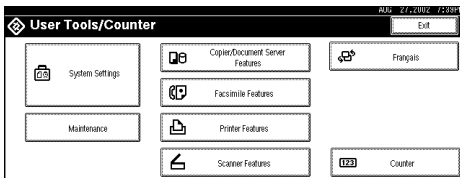

3 Press **[List/Test Print]**.

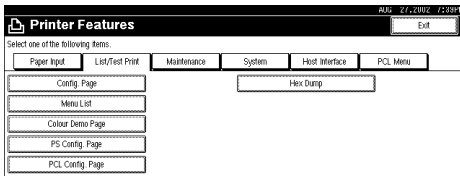

4 Press **[Config. Page]**.

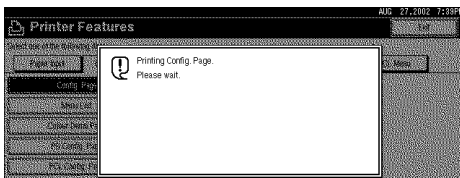

The configuration page is printed.

Note

- If printing is not normal, check to see if an error message is shown on the panel display. If there is an error message, see "Troubleshooting" in Maintenance Guide 2 Copier System Edition.
- For more information about the configuration page, see "Interpreting the Configuration Page" in Administrator Reference 2 Copier System Edition.

5 Press the **[User Tools/Counter]** key.

The initial display is shown.

3. Setup Guide for each Network Environment

Printing with a Print Server

Printing with a Windows 2000 or Windows NT 4.0 Print Server

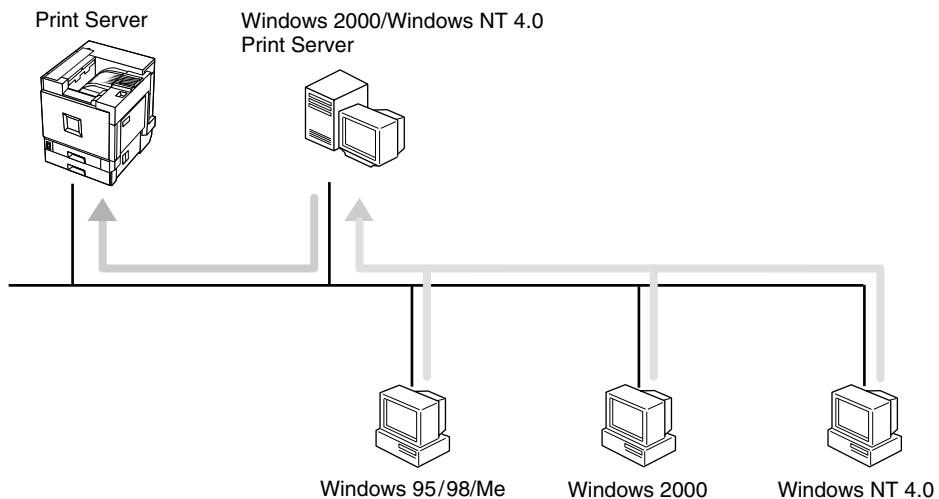

- 1** Choose a protocol for the printer and print server.
- 2** Configure a protocol you want to use with the control panel.
⇒ p.23 "Configuring the Network with the Control Panel".
- 3** Configure the printer.
⇒ "Windows 2000 Configuration" and "Windows NT 4.0 Configuration" in Administrator Reference 2 Copier System Edition.
- 4** Install the printer driver and SmartNetMonitor for Client.
⇒ "Windows 2000 Configuration" and "Windows NT 4.0 Configuration" in Administrator Reference 2 Copier System Edition.
- 5** Share the printer.
⇒ "Windows 2000 Configuration" and "Windows NT 4.0 Configuration" in Administrator Reference 2 Copier System Edition.

Printing with a NetWare Print Server

Set up a network printer in a NetWare environment.

For more information about setting up the clients, see "*NetWare Configuration*" in Printer Client Reference 2.

Configuring the Printer as a Print Server

3

A dedicated NetWare print server is not required because the printer can be configured as a print server.

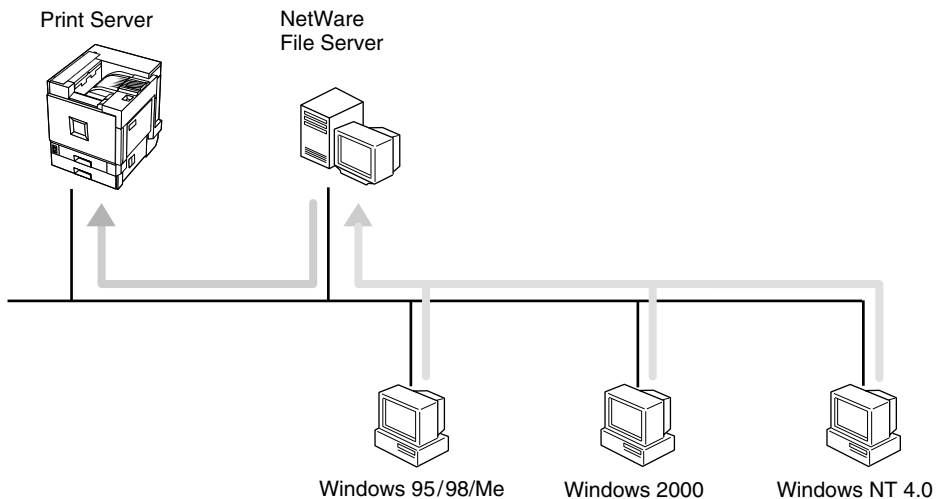

1 Configure the printer for NetWare with the control panel.

⇒ p.23 "Configuring the Network with the Control Panel".

2 Configure NetWare. The procedure may vary depending on the NetWare version.

⇒ "NetWare Configuration" in Administrator Reference 2 Copier System Edition.

Configuring the Printer as a Remote Printer

If a dedicated NetWare print server is being used, the printer should be configured as a remote printer.

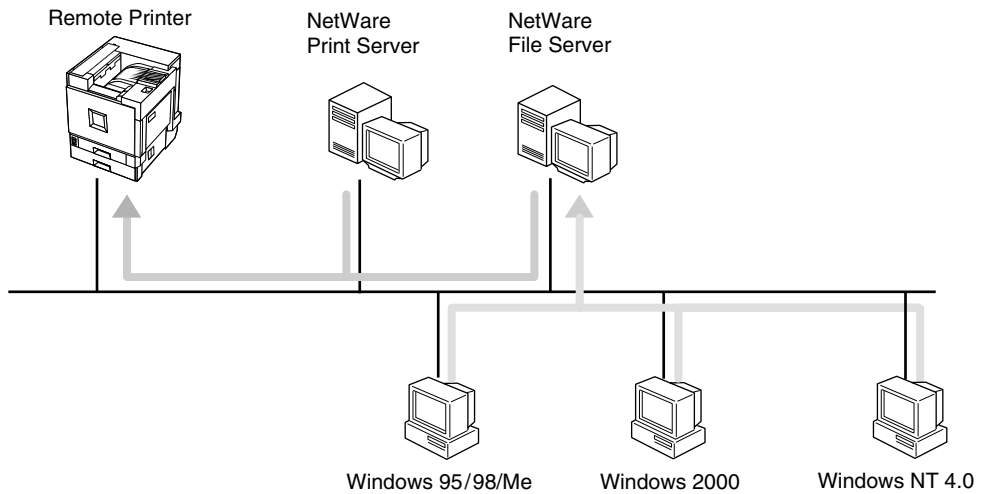

3

- 1** Configure the printer for NetWare with the control panel.
- 2** Configure NetWare. The procedure may vary depending on the NetWare version.
⇒ "NetWare Configuration" in Printer Client Reference 2.

Printing without Using a Print Server

3

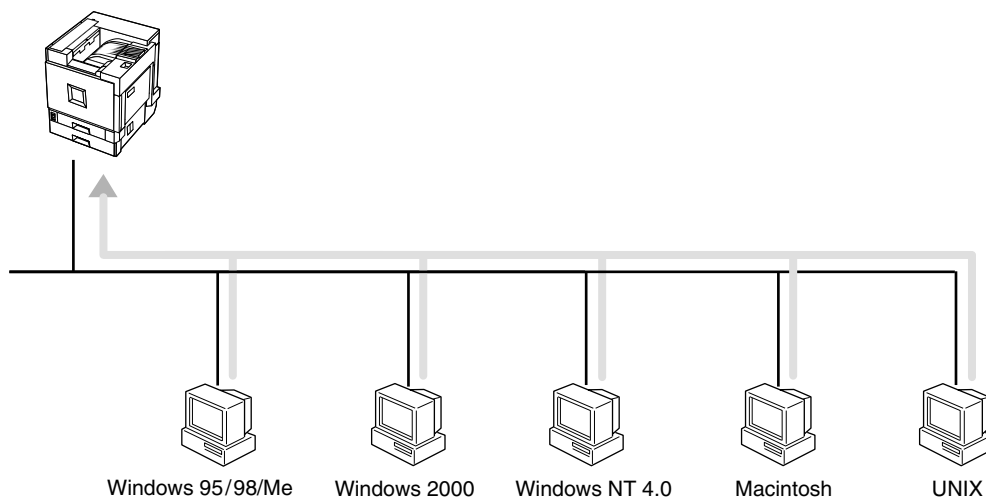

- 1** Choose a protocol for the printer and print server.
- 2** Configure a protocol you want to use with the control panel.
⇒ p.23 “Configuring the Network with the Control Panel”.

4. Combined Function Operations

Copy Mode

You can make basic copies, and enlarge/reduce, combine, or use other various functions to make copies. You can also add options to further increase the number of functions. For more details, see the Copy Reference.

Changing to Copy Mode

You can always make a copy when the machine isn't printing or scanning originals for faxes.

1 Press the **[Copy]** key.

The copier display appears on the panel display.

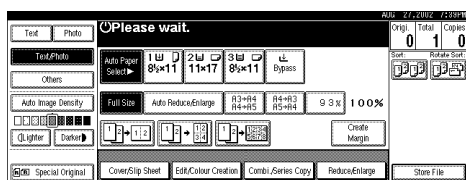

Reference

For more information, see the Copy Reference <Basic Features>.

Interrupt copying to make urgently needed copies

You can interrupt the current job to make a copy.

Note

- The display may vary depending on the settings described on "User Tools (System Settings)" in Administrator Reference 2 Copier System Edition.

Limitation

- You cannot use the interrupt copy function in the following cases:
 - During fax immediate transmission
 - While scanning an original for memory transmission
 - During interrupt copying

When Scanning in the Copy or Document Server

During copying or scanning into the document server, you can use the following procedure to interrupt the current job and make a copy.

Limitation

- During interrupt copying, you cannot perform another interrupt copying.

1 Press the **[Interrupt]** key

If the machine is scanning originals, the scanning job will stop immediately and the interrupt display will appear on the panel display.

2 Remove the previous original and place the new original to be done by interrupt copying.

3 Press the **[Start]** key.

Interrupt copying starts.

4 After interrupt copying is complete, remove the original and delivered copies.

5 Press the **[Interrupt]** key again.

The display shown before interrupt copying started reappears.

6 Replace the previous original, and then press the **[Start]** key.

The previous job settings will be restored and the machine will continue from where it left off.

Printing with Copier, Document Server, Facsimile or Printer

During printing, you can use the following procedure to interrupt the current job and make a copy.

1 Press the **[Interrupt]** key.

The interrupt display appears on the panel display.

Note

- Printing does not stop yet.

2 Place the originals used for interrupt copying, and then press the **[Start]** key.

Printing stops and interrupt copying starts.

3 When copying is complete, remove the originals and the copies.

4 Press the **[Interrupt]** key.

The display shown before interrupt copying started reappears.

5 Replace the previous original, and then press the **[Start]** key.

Document Server Mode

The Document Server stores scanned copies and scanned documents for faxing. You can also combine stored jobs and print them.

In addition, you can forward stored fax transmissions.

! Limitation

- The Document Server function requires the optional Hard Disk Unit.

📝 Note

- If you want to re-send fax documents, go back to the Facsimile display.

🔍 Reference

For more information about the Document Server, see "*Document Server*" in Administrator Reference 2 Copier System Edition.

4

Copying by Using the Document Server

You can print from the Document Server while using other functions.

1 Press the **[Document Server]** key.

The Document Server display appears on the panel display.

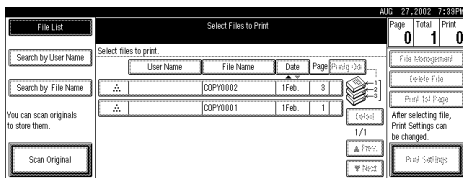

2 Select the desired documents, and then press **[OK]**.

📝 Note

- If the optional SR770 (2 Tray Finisher) or PT460 (Multi-bin) is installed on the machine, you can specify an output tray to which to deliver documents. For more information, see "*User Tools (System Settings)*" in Administrator Reference 2 Copier System Edition.

Storing Documents in the Document Server

Storing Documents in the Document Server

1 Place originals.

2 Press the **[Document Server]** key.

The Document Server display appears on the panel display.

3 Press **[Scan Original]**.

4 Press the **[Start]** key.

Documents are stored for the Copier function.

4

Storing Documents while Copying

You can copy while storing files.

1 Place originals.

2 Press the **[Copy]** key.

The Copier display appears on the panel display.

3 Press **[Store File]**, and then press **[OK]**.

4 Press the **[Start]** key.

Both copying and storing documents will be started.

Storing Documents from the Fax Display

You can select to store and transmit documents at the same time or store documents only.

! **Limitation**

- Documents stored with the Facsimile function do not appear in the file list of the Document Server display. For more information, see the Facsimile Reference <Advanced Features>.

1 Place originals.

2 Press the **[Facsimile]** key.

The Facsimile display appears on the panel display.

3 Press the **[Store File]** key.

4 Press **[Store & Transmit]** or **[Store only]**, and then press the **[OK]** key.

5 If you selected **[Store & Transmit]**, enter the numbers. If you selected **[Store only]**, go to step **6**.

6 Press the **[Start]** key.

If you selected **[Store & Transmit]**, the machine starts storing documents and transmitting them. If you selected **[Store only]**, the machine starts storing documents.

Reference

For more information about this function, see "*Using the Document Server*" in the Facsimile Reference <Advanced Features>.

Interrupt the Operating Function and Start Storing

Even if another function is operating, you can use the Document Server. Refer to the following procedure.

While Copying

1 Press the **[Clear/Stop]** key.

The copy job will be interrupted.

2 Remove the originals.

3 Press the **[Document Server]** key.

The Document Server display appears on the panel display.

4 Place originals to be stored.

5 Press **[Scan Original]**.

The machine starts storing documents.

Note

- After using the Document Server, press the **[Copy]** key to resume the interrupted job.

Facsimile Mode

Changing to Facsimile Mode

1 Press the **[Facsimile]** key.

The Facsimile display appears on the panel display.

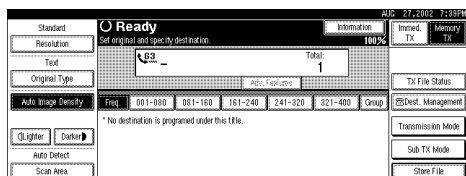

4

Note

- The Memory Transmission/Reception function is performed automatically even when another function is being used. You need not switch the display. When data is received in memory, the Receive File indicator is lit.

Reference

For more information, see the Facsimile Reference <Basic Features>.

Printer Mode

Changing to Printer Mode

To print from an application being run on a personal computer, you need not switch to Printer mode on this machine. You must switch to Printer mode, however, to perform the following operations:

- Form Feed
- Job Reset
- Sample Print
- Locked Print

1 Press the **[Printer]** key.

The Printer display appears on the panel display.

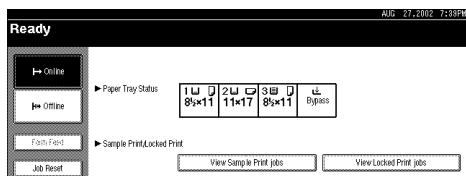

Printing

The machine can receive print data while another mode is functioning.

Note

- If "Function Priority" in the System Settings is not set as "Printer", printing is done after the current job. For more information, see "User Tools (System Settings)" in Administrator Reference 2 Copier System Edition.

1 Print the job from your computer.

Printing starts.

Note

- If User Codes have been set for the Printer function as described in Administrator Reference 2 Copier System Edition, you must enter your User Code from the Printer Driver.

Scanner Mode

Changing to Scanner Mode

This optional Scanner Unit has two scanner functions: “Network TWAIN Scanner” and “Network Delivery Scanner”.

Reference

To configure the function priority, see the Scanner Reference.

Limitation

- In the following cases, the machine cannot be used as a scanner.
 - While scanning originals for copying
 - While scanning a fax message for transmission
 - During Immediate Fax transmission

4

Using the Network TWAIN Scanner

- 1** Place originals.
- 2** Configure the scan options using the computer.
- 3** Start the scan.

Reference

For more information, see the Scanner Reference.

Using the Network Delivery Scanner

- 1** Place originals.
- 2** Press the **[Scanner]** key.
The Scanner display appears on the panel display.

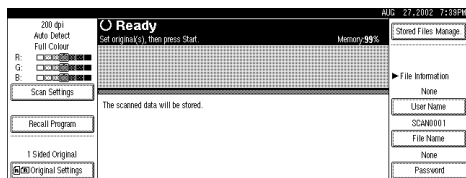

- 3** Specify **[Scan Settings]** or **[Original Settings]**.
- 4** Press the **[Start]** key.

Reference

For more information, see the Scanner Reference.

Interrupting Scanning

If you want to scan while copying or faxing, follow the procedure below.

Scanning while copying

Usually, you cannot use this machine as a scanner until it finishes copying.

1 Press the **[Clear/Stop]** key.

Copying is interrupted.

2 Remove the originals.

3 Start the scan.

 **Note**

When the scan is completed, press the **[Copy]** key and restart copying.

Scanning while scanning a fax message for memory transmission

Usually, you cannot use the Scanner function until scanning a fax message for memory transmission is completed.

1 Press **[Clear/Stop]** key.

The fax message scan is interrupted.

 **Note**

When using Quick Memory delivery, previously scanned originals will be delivered. For more information, see the Facsimile Reference.

2 Remove the originals.

3 Start the scan.

 **Note**

When the scan is completed, press the **[Facsimile]** key and restart faxing.

Scanning while doing an Immediate Fax Transmission

Usually, you cannot use the Scanner function while it is doing Immediate Fax transmissions.

Preparation

Select Function Reset Timer to set "Instant". For more information, see "*User Tools (System Settings)*" in Administrator Reference 2 Copier System Edition.

1 Press **[Clear/Stop]** key.

The immediate fax transmission is interrupted.

Note

- Previously scanned originals will be delivered.

2 Remove the originals.

3 Start the scan.

Note

- When the scan is completed, press the **[Facsimile]** key and restart faxing.

Scanning while printing

You can scan without interrupting printing.

Multi-Access

You can carry out another job using a different function while the current job is being performed.

This allows you to handle your jobs efficiently regardless of how the machine is being used. For example:

- While making copies, you can scan documents to store in the Document Server.
- While printing documents saved in the Document Server, the machine can receive print data.
- You can make copies while receiving fax data.
- While printing print data, you can make operations for copying.

Performing multiple functions simultaneously like this is called Multi-accessing.

Note

- ❑ To specify which function to give priority to, use **[Print Priority]**. The factory setting is **[Copy]**. For more information, see "*User Tools (System Settings)*" in Administrator Reference 2 Copier System Edition.
- ❑ If the optional SR770 (2 Tray Finisher) or PT460 (Multi-bin) is installed on the machine, you can specify an output tray to which to deliver documents. For more information, see "*User Tools (System Settings)*" in Administrator Reference 2 Copier System Edition.

Multi-Access Operation

⊙: If the desired operation is set as "Function Priority", it interrupts the current operation after the current page has been completed. If the current operation is set as "Function Priority", the interrupting operation is carried out automatically after the current operation ends.

○: If the desired operation is set as "Function Priority", it interrupts the current operation after the current job has been completed. If the current operation is set as "Function Priority", the interrupting operation is carried out automatically after the current operation ends.

●: Operation is enabled when a function key or the **[Interrupt]** key is pressed, or remote switching (when scanning) is carried out.

▲: The operation is enabled by pressing the **[Interrupt]** key to interrupt the current operation.

×: The operation can only be started after the current operation ends. (Operations cannot be carried out at the same time.)

Desired Operation	Copy (including "Store File" operation)				Interrupt Copy		Fax				Printer				Scanner			
	Operation	Copy	Copy with staple	Copy with sort	Operation	Copy	Send		Receive		Data in	Print			Operation	Scan		
							Scan originals when memory transmission	Memory transmission	Immediate transmission	Reception		Print a received file	Print	Print with collating			Print with stapling	
Current Operation	Color mode	B W	C L	B W	C L	B W	C L	B W	C L	B W	C L	B W	C L	B W	C L	B W	C L	
Copy	Operating	B W	C L	×	×	×	×	●	●	●	●	○	○	○	○	○	○	○
	Copying (when scanning)	B W	C L	○	▲	▲	▲	●	●	●	○	○	○	○	○	○	○	○
	Copying (when printing)	B W	C L	○	▲	▲	▲	●	●	●	○	○	○	○	○	○	○	○
	Copying with staple (when scanning first set)	B W	C L	○	▲	▲	▲	●	●	●	○	○	○	○	○	○	○	○
	Copying with staple (when printing second set)	B W	C L	○	▲	▲	▲	●	●	○	○	○	○	○	○	○	○	○
	Copying with sort (when scanning first set)	B W	C L	○	▲	▲	▲	●	●	●	○	○	○	○	○	○	○	○
	Copying with sort (when printing second set)	B W	C L	○	▲	▲	▲	●	●	○	○	○	○	○	○	○	○	○
Interrupt Copy	Operation	B W	C L	×	×	×	×	×	×	○	×	○	▲	▲	▲	×	×	×
	Copying	B W	C L	×	×	×	×	×	×	○	×	○	▲	▲	▲	×	×	×
Fax	Operating a transmission	B W	C L	●	●	●	●	●	●	×	×	○	○	○	○	○	○	○
	Send	Scanning (when memory transmission)	B W	C L	×	×	×	×	×	×	○	×	○	○	○	○	○	○
		Memory transmitting	B W	C L	○	○	○	○	○	○	○	▲	×	×	○	○	○	○
		Immediate transmitting	B W	C L	×	×	×	×	×	×	×	×	×	×	○	○	○	○
	Receive	Receiving	B W	C L	○	○	○	○	○	○	×	×	×	○	○	○	○	○
Printing (received file, etc)		B W	C L	○	○	○	○	●	●	○	○	○	○	○	○	○	○	○
Printer	Data in	B W	C L	○	○	○	○	○	○	○	○	○	○	○	○	○	○	○
		B W	C L	○	○	○	○	○	○	○	○	○	○	○	○	○	○	○
	Print	Printing	B W	C L	○	○	○	○	●	●	○	○	○	○	○	○	○	○
		Printing with collate	B W	C L	○	○	○	○	●	●	○	○	○	○	○	○	○	○
Printing with staple	B W	C L	○	○	○	○	●	●	○	○	○	○	○	○	○	○	○	
Scanner	Operating	B W	C L	●	●	●	●	●	●	○	○	○	○	○	○	○	○	○
	Scanning	B W	C L	×	×	×	×	×	×	×	×	○	○	○	○	○	○	○
		B W	C L	×	×	×	×	×	×	○	○	○	○	○	○	○	○	○

JCF-ZFEH850E

*1 BW = Black & White, CL = Color Mode

*2 If a fax is being received, the operation is not performed until reception is complete.

*3 Scanning is "Print Priority".



Information about Installed Software

expat

Expat(Version 1.1). Copyright 1998, 1999 James Clark. All rights reserved.

- The software installed on this product includes the expat application software Version 1.1 (hereinafter "expat 1.1").
- The product manufacturer has not made any modification to the source code of the expat 1.1.
- The product manufacturer provides warranty and support to the software of the product including the expat 1.1 and the product manufacturer makes Mr. James Clark, the initial developer of the expat 1.1, free from these obligations.
- The expat 1.1 is made available under Mozilla Public License Version 1.1 (hereinafter "MPL 1.1"), and controller software of the product equals the Larger Work as defined in MPL 1.1. The software of this product except the expat 1.1 is licensed to the product manufacturer under separate agreement(s).
- The source code of the expat 1.1 is available at:
ftp://ftp.jclark.com/pub/xml/expat1_1.zip
- MPL 1.1 is also available at:
<http://www.mozilla.org/MPL/MPL-1.1.html>
- Information relating to the expat 1.1 is available at:
<http://www.jclark.com/xml/expat.html>

NetBSD

Copyright Notice of NetBSD

For all users to use this product:

This product contains NetBSD operating system:

For the most part, the software constituting the NetBSD operating system is not in the public domain; its authors retain their copyright.

The following text shows the copyright notice used for many of the NetBSD source code. For exact copyright notice applicable for each of the files/binaries, the source code tree must be consulted.

A full source code can be found at <http://www.netbsd.org/>.

Copyright © 1999, 2000 The NetBSD Foundation, Inc.

All rights reserved.

Redistribution and use in source and binary forms, with or without modification, are permitted provided that the following conditions are met:

- ① Redistributions of source code must retain the above copyright notice, this list of conditions and the following disclaimer.
- ② Redistributions in binary form must reproduce the above copyright notice, this list of conditions and the following disclaimer in the documentation and/or other materials provided with the distribution.
- ③ All advertising materials mentioning features or use of this software must display the following acknowledgment:
This product includes software developed by the NetBSD Foundation, Inc. and its contributors.
- ④ Neither the name of The NetBSD Foundation nor the names of its contributors may be used to endorse or promote products derived from this software without specific prior written permission.

THIS SOFTWARE IS PROVIDED BY THE NETBSD FOUNDATION, INC. AND CONTRIBUTORS "AS IS" AND ANY EXPRESS OR IMPLIED WARRANTIES, INCLUDING, BUT NOT LIMITED TO, THE IMPLIED WARRANTIES OF MERCHANTABILITY AND FITNESS FOR A PARTICULAR PURPOSE ARE DISCLAIMED. IN NO EVENT SHALL THE FOUNDATION OR CONTRIBUTORS BE LIABLE FOR ANY DIRECT, INDIRECT, INCIDENTAL, SPECIAL, EXEMPLARY, OR CONSEQUENTIAL DAMAGES (INCLUDING, BUT NOT LIMITED TO, PROCUREMENT OF SUBSTITUTE GOODS OR SERVICES; LOSS OF USE, DATA, OR PROFITS; OR BUSINESS INTERRUPTION) HOWEVER CAUSED AND ON ANY THEORY OF LIABILITY, WHETHER IN CONTRACT, STRICT LIABILITY, OR TORT (INCLUDING NEGLIGENCE OR OTHERWISE) ARISING IN ANY WAY OUT OF THE USE OF THIS SOFTWARE, EVEN IF ADVISED OF THE POSSIBILITY OF SUCH DAMAGE.

Authors Name List

All product names mentioned herein are trademarks of their respective owners. The following notices are required to satisfy the license terms of the software that we have mentioned in this document:

- This product includes software developed by the University of California, Berkeley and its contributors.
- This product includes software developed by Jonathan R. Stone for the NetBSD Project.
- This product includes software developed by the NetBSD Foundation, Inc. and its contributors.
- This product includes software developed by Manuel Bouyer.
- This product includes software developed by Charles Hannum.
- This product includes software developed by Charles M. Hannum.
- This product includes software developed by Christopher G. Demetriou.

- This product includes software developed by TooLs GmbH.
- This product includes software developed by Terrence R. Lambert.
- This product includes software developed by Adam Glass and Charles Han-num.
- This product includes software developed by Theo de Raadt.
- This product includes software developed by Jonathan Stone and Jason R. Thorpe for the NetBSD Project.
- This product includes software developed by the University of California, Lawrence Berkeley Laboratory and its contributors.
- This product includes software developed by Christos Zoulas.
- This product includes software developed by Christopher G. Demetriou for the NetBSD Project.
- This product includes software developed by Paul Kranenburg.
- This product includes software developed by Adam Glass.
- This product includes software developed by Jonathan Stone.
- This product includes software developed by Jonathan Stone for the NetBSD Project.
- This product includes software developed by Winning Strategies, Inc.
- This product includes software developed by Frank van der Linden for the NetBSD Project.
- This product includes software developed for the NetBSD Project by Frank van der Linden
- This product includes software developed for the NetBSD Project by Jason R. Thorpe.
- The software was developed by the University of California, Berkeley.
- This product includes software developed by Chris Provenzano, the University of California, Berkeley, and contributors.

JPEG Library

The software installed on this product is based in part on the work of the Independent JPEG Group.

INDEX

10BASE-T/100BASE-TX, 13

C

Caution, ii
Combined Function Operations, 37
Configuring the Network, 22
Control Panel, 6
Copy Mode, 37

D

Document Server Mode, 39

F

Facsimile Mode, 42

I

IEEE 1394 Ports (option), 13
Interrupt Copying, 37

M

Main power switch, 19
Multi-Access, 47

N

Network Connections, 14

O

Operation switch, 19

P

Parallel Connection, 16
Parallel Port, 13
Printer Mode, 43
Printing without Using a Print Server, 36
Print with a Print Server, 33
 NetWare Print Server, 34
 Windows 2000/Windows NT 4.0
 Print server, 33

S

Safety Information, ii
Scanner Mode, 44
Setup Guide for each Network
 Environment, 33

W

Warning, ii

Note to users in the United States of America

Notice:

This equipment has been tested and found to comply with the limits for a Class B digital device, pursuant to Part 15 of the FCC Rules. These limits are designed to provide reasonable protection against harmful interference in a residential installation. This equipment generates, uses and can radiate radio frequency energy and, if not installed and used in accordance with the instructions, may cause harmful interference to radio communications.

However, there is no guarantee that interference will not occur in a particular installation. If this equipment does cause harmful interference to radio or television reception, which can be determined by turning the equipment off and on, the user is encouraged to try to correct the interference by one more of the following measures:

Reorient or relocate the receiving antenna.

Increase the separation between the equipment and receiver.

Connect the equipment into an outlet on a circuit different from that to which the receiver is connected.

Consult the dealer or an experienced radio/TV technician for help.

Warning

Changes or modifications not expressly approved by the party responsible for compliance could void the user's authority to operate the equipment.

Caution (in case of 100BaseTX environment):

Properly shielded and grounded cables (STP) and connectors must be used for connections to host computer (and/or peripheral) in order to meet FCC emission limits.

Declaration of Conformity

Product Name: Laser Printer

Model Number: AP3800C/AP828/SLP38c/DSc38

Responsible party: Ricoh Corporation

Address: 5 Dedrick Place, West Caldwell, NJ 07006

Telephone number: 973-882-2000

This device complies with part 15 of FCC Rules.

Operation is subject to the following two conditions:

1. This device may not cause harmful interference, and
2. this device must accept any interference received, including interference that may cause undesired operation.

Properly shielded cables must be used for connections to host computer (and/or peripheral) in order to meet FCC emission limits.

Network interface cable with ferrite core must be used for RF interference suppression.

Note to users in Canada

Note:

This Class B digital apparatus complies with Canadian ICES-003.

Remarque concernant les utilisateurs au Canada

Avertissement:

Cet appareil numérique de la classe B est conforme à la norme NMB-003 du Canada.

In accordance with IEC 60417, this machine uses the following symbols for the main power switch:

I means POWER ON.

O means POWER OFF.

⏻ means STAND-BY

